

Assembling instructions
Montage Anweisungen
Montaje instructie
Noticia de montagen
Istruzioni per il montaggio
Instruções de montagem

TOPWOOD

Gamme TOPWOOD avec plate forme - H 2,30m

TRIGANO JARDIN
Usine du Boulay
41170 - Cormenon, France
www.triganojardin.com

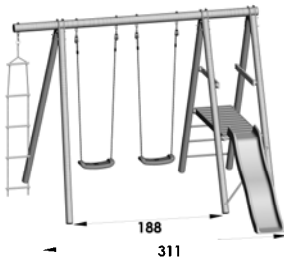

Réf.16541P6
Réf.16541P1

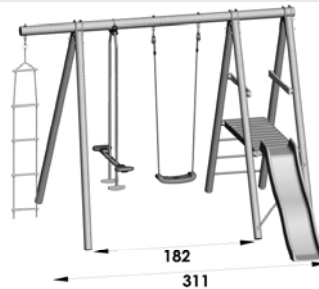

Réf.16544P6
Réf.16544P1

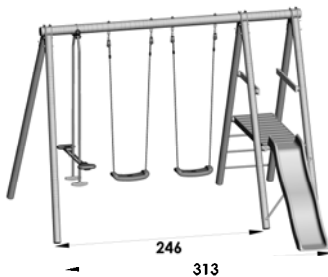
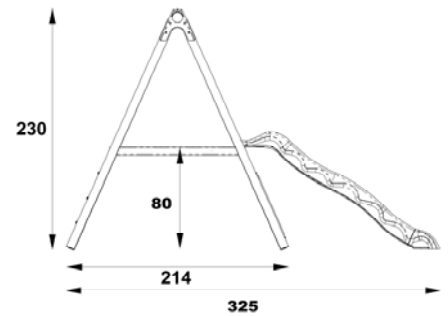

TO605

Réf.16652P6

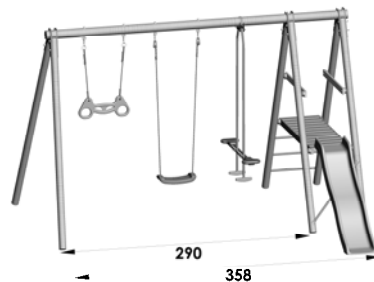

TO607

Réf.16654P6

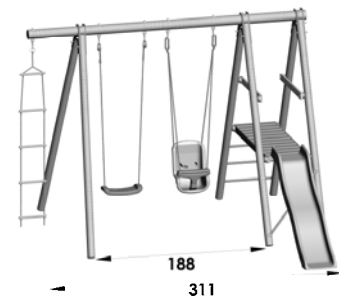

Réf.16546P6

Attention ! – Warning – Achtung – Attenzione – Atencion - Atenção



- F** A LIRE IMPERATIVEMENT AVANT DE COMMENCER LE MONTAGE DE VOTRE PRODUIT - SCHELLEMENT BETON IMPERATIF
Réservé à un usage familial en extérieur.
- GB** IT IS ESSENTIAL TO READ THE MANUAL BEFORE STARTING TO ASSEMBLY YOUR PRODUCT - MUST BE FIXED IN CONCRETE
Only for domestic use, for outdoor.
- D** VOR DER MONTAGE DES ARTIKELS UNBEDINGT DURCHLESEN - MUSS UNBEDINGT EINBETONIERT WERDEN
Ausschließlich für den Privatgebrauch im Frien.
- NL** LEES DIT VERPLICHT EN GRONDIG DOOR VOORDAT U UW TOESTEL GAAT MONTEREN - HET IS NOODZAKELIJK TE BEVESTIGEN
MET GRONDANKERS. Uitsluitend voor gebruik in de gezinskkring buitens huis.
- I** LEGGERE ATTENTAMENTE PRIMA DI INIZIARE IL MONTAGGIO DEL PRODOTTO - ESSERE FISSATO SALDAMENTE NEL CEMENTO
Sólo para uso doméstico en exteriores.
- SP** DE LECTURA IMPRESINDIBLE ANTES DE EMPEZAR CON EL MONTAJE DEL PRODUCTO - EMPOTRAMIENTO IMPERATIVO
Utilizzo esclusivamente familiare, per esterni.
- P** A LER IMPERATIVAMENTE ANTES DE COMECAR A MONTAGEM DO SEU PRODUTO - - O CHUMBAMENTO É IMPERATIVO
Exclusivamente para uso familiar no exterior.

- F** Veuillez garder impérativement la notice de montage qui vous sera utile pour l'entretien de votre produit. Aucune modification ne doit être apportée sur le produit. Pour l'entretien du produit n'utiliser que des pièces d'origine.
- GB** It is imperative that you keep the assembling instructions, which be of use for product maintenance. Not to bring modifications to the product, and any change must be made with parts of origine.
- D** Bewahren Sie unbedingt die Montageanleitung auf, die Sie zur Wartung und Pflege Ihres Artikels brauchen.
- NL** Bewaar de gebruiksaanwijzing zorgvuldig, deze zal nuttig zijn voor het onderhoud van uw produkt.
- P** Guarde imperativamente as intruções de montagem, que serão úteis para a manutenção do seu produto.
- I** Conservare il manuale di montaggio per le ulteriori operazioni di manutenzione.
- SP** Conserve cuidadosamente las intrucciones de montaje, ya que le servirán para el mantenimiento de su producto.

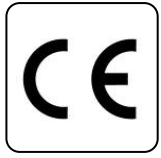

- F** Zone de sécurité : 2,00 m.
- aucun objet en appui sur le produit
- Recouvrir le béton de 5 cm de terre meuble
- UK** Safety area : 2,00 m.
- No object around the product
- Cover the concrete dies with a 5cm layer of soil
- D** Sicherheitsbereich: 2,00 m.
- Kein Gegenstände in der Nähe der Rutsche belassen
- 5cm Rasenüberdeckung erforderlich im Leiterbereich und im Auslaufbereich
- NL** Veiligheidszone : 2,00 m.
- Geen enkel voorwerp rondom het toestel
- Bedek de betonblokken met 5cm losse aarde
- I** Zona di sicurezza : 2,00 m.
- Nessun oggetto intorno al prodotto
- Ricoprire i dadi in cemento di 5cm terra mobile
- SP** Area de seguridad : 2,00 m.
- Ningún objeto alrededor del producto
- Recubrir el hormigón con 5cm de tierra blanda
- P** Zona de segurança : 2,00 m.
- Nenhum objecto em redor do produto
- Abranger o betão de 5cm de terra móvel.

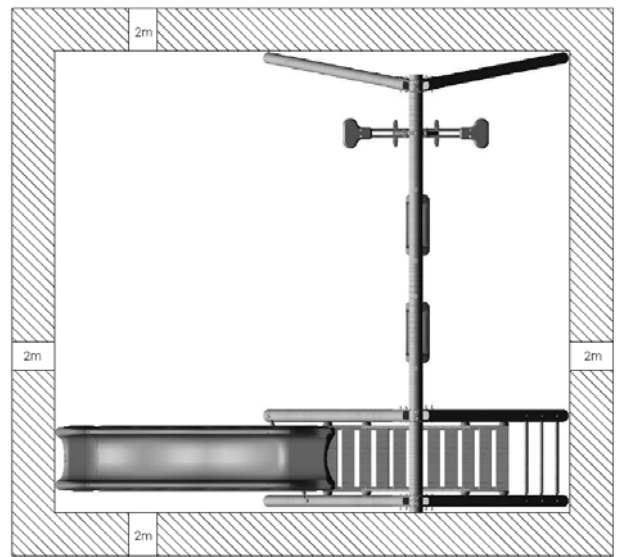

F - Votre balançoire est prévue pour être montée sur des portiques de hauteurs différentes. Avant d'utiliser votre portique et régulièrement par la suite, contrôler que le dessous du siège de balançoire est toujours compris entre 35 et 50cm par rapport au sol. Si ce n'est pas le cas, procéder impérativement à ce réglage.

GB -Your swing is designed to be gone up on gantries of different sizes. Before using your gantry and regularly there after, controlling that the lower part of the seat of swing always lies between 35 and 50cm compared to the ground. If it is not the case, to carry out this adjustment imperatively.

D - Ihre Schaukel ist vorgesehen, um auf Säulenhallen anderer Größen aufgerichtet zu werden. Bevor Ihre Säulenhalle und regelmäßig später zu benutzen zu kontrollieren, dass die Unterseite des Schaukelsitzes immer zwischen 35 und 50 gelegen wird cm hinsichtlich des Bodens. Wenn es nicht der Fall, diese Einstellung dringend durchzuführen ist.

NL- Uw schommel is voorzien om op portalen van verschillende omvang gestegen te zijn. Alvorens uw portaal te gebruiken en regelmatig vervolgens, controleren dat de onderkant van de zetel van schommel altijd tussen 35 en 50cm ten opzichte van de bodem wordt omvat. Als het niet het geval, verplicht tot dit regelen overgaan is.

I - La vostra altalena è prevista per essere montata su cavalletti di dimensioni diverse. Prima di utilizzare il vostro cavalletto e regolarmente successivamente, controllare che il sotto della sede d'altalena è sempre compreso tra 35 e 50cm rispetto al suolo. Se non è il caso, procedere imperativamente a questa messa a punto.

SP - Su columpio está previsto subirse sobre pórticos de tamaños diferentes. Antes de utilizar su pórtico y regularmente más tarde, controlar que la parte inferior de la sede de columpio siempre se incluye entre 35 y 50cm con relación al suelo. Si no es el caso, proceder imperativamente a este ajuste.

P - O vosso baloiço está previsto para ser montado sobre pórtico de dimensões diferentes. Antes de utilizar o vosso pórtico e regularmente seguidamente, controlar que o abaixo da sede de baloiço sempre é compreendido entre 35 e 50 cm em relação ao solo. Se não é o caso, proceder imperativamente à este ajustamento.

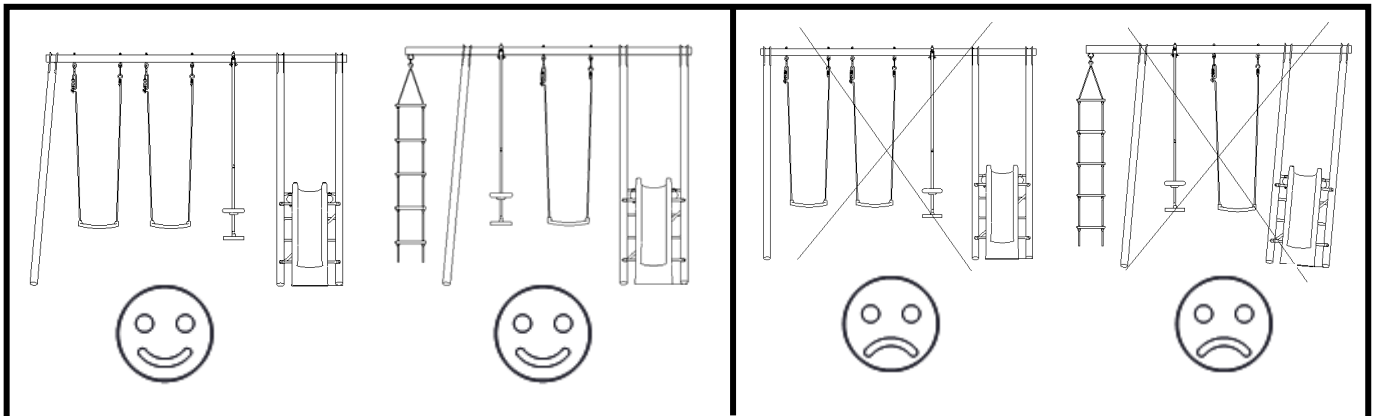
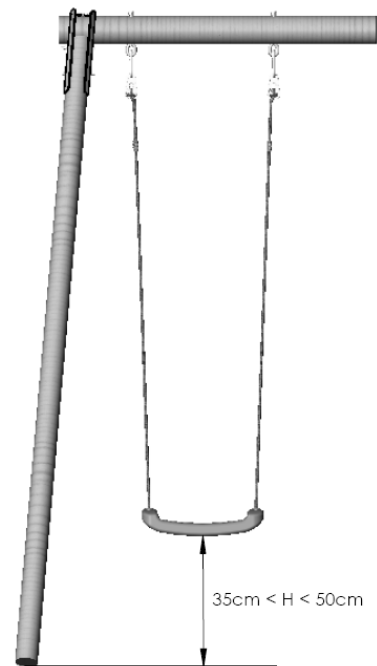

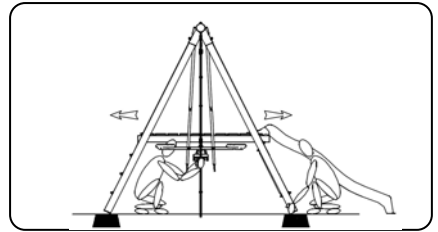
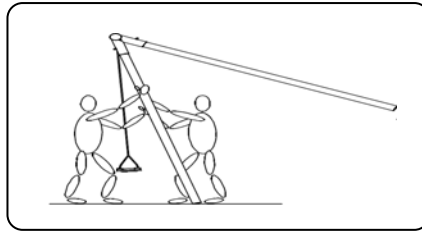
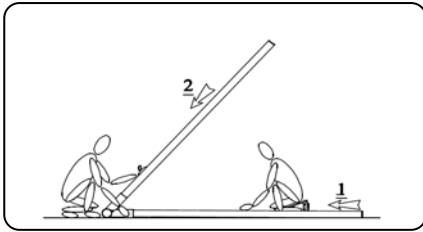

- Scellement béton impératif
- Must be fixed in concrete
- Muss unbedingt einbetoniert werden
- Het is noodzakelijk te bevestigen met grondankers
- O chumbamento é imperativo
- Essere fissato saldamente nel cemento
- Empotramiento imperativo

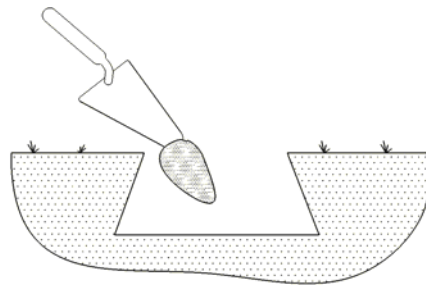
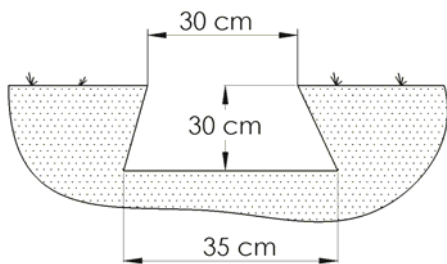
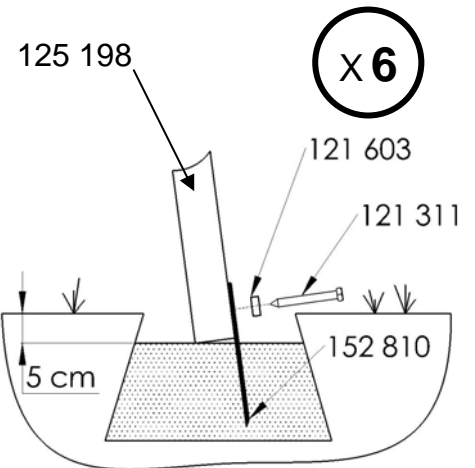

FR - Pour mesurer les écartements entre les pieds avant de faire vos plots de scellement, tirer modérément les pieds vers l'extérieur du portique pour être sûr d'obtenir l'angle de 95° minimum (comme figure ci-contre).

GB - Pull the feet a little bit away from the frame to ensure the angle is at least 95° (see figure below) before measuring the distance between the feet and making your mounting blocks.

DE - Um den Abstand zwischen den Füßen zur Bestimmung der Verankerungspunkte zu bemessen, die Füße des Gerüsts leicht nach außen ziehen, um sicherzugehen, dass der Winkel mindestens 95° beträgt (siehe Abbildung oben).

NL - Voor u de afstandblokjes vastmaakt, moet de afstand ertussen gemeten worden. Trek zachtjes de poten naar de buitenzijde van de speelconstructie zodat u een minimale hoek van 95° hebt (zie figuur hierboven).

ES - Para medir las separaciones entre los pies antes de realizar sus juntas de sellado, tire moderadamente de los pies hacia afuera del pórtico para asegurarse de que tiene un ángulo de 95° como mínimo (como figura más arriba).

IT - Per misurare lo scarto tra i piedi prima di procedere al fissaggio definitivo, tirare con moderazione i piedi verso l'esterno della struttura per essere sicuri di avere un angolo di minimo 95° (come mostrato dalla figura qui sopra).

PO - Para medir as distâncias entre os pés antes de fazer os blocos de fixação, puxar moderadamente os pés para o exterior do pórtico para ter a certeza de ter um ângulo de 95° mínimo (como figura acima).

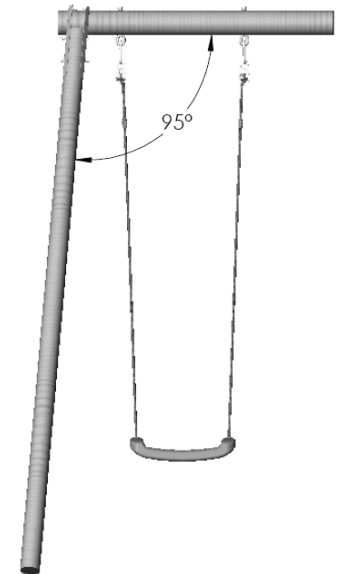

--	--	--	--	--	--

F Nous vous précisons que le bois est un produit naturel qui réagit aux variations de température et d'humidité. Des fissures et des fentes peuvent apparaître. C'est tout à fait normal et cela n'affecte en rien la solidité, la durée de vie ou la garantie de ce produit.

UK Please be aware, wood is a natural product that re-acts to temperature and humidity variations. Splits and cracks will occur. This is completely normal and does not affect the integrity of your product or your warranty.

D Wir erinnern Ihnen, dass das Holz natürlich ist. Es kann sein, dass einige Ritze wegen Feuchtigkeitsveränderungen erscheinen. Das ist ganz normal und das verschlechtert überhaupt nicht die Festigkeit, Lebensdauer oder die Garantie dieses Produkts.

NL Wij wijzen er op dat hout een natuurlijk product is dat reageert op temperatuur-en vochtigheidsverschillen. Er kunnen scheurtjes en gleuven optreden. Dit is normaal en doet niets af aan de degelijkheid, de levensduur of de garantie van dit product.

I Indicamos-ihe que a madeira é um produto natural que reage às variações de temperatura e de humidade. Rachas e fendas podem aparecer. É normal e isso não afecta em nada a solidez, a duração de vida ou a garantia deste produto.

SP Precisiamo che il legno è un prodotto naturale che reagisce alle variazioni di temperatura e di umidità. Possono apparire delle fessure e delle crepe. Ciò è del tutto normale e non ha alcun effetto sulla solidità, la durata di vita o la garanzia di questo prodotto.

P Le recordamos que la madera es un producto natural que reacciona a las variaciones de temperatura y humedad. Pueden aparecer fisuras o grietas. Es normal y no afecta en absoluto a la solidez, la vida útil o la garantía del producto.

16541P6
16541P1

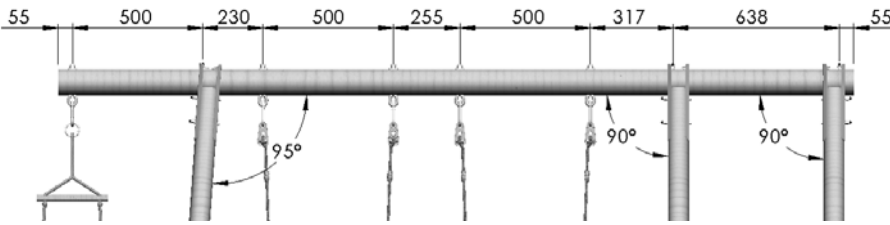

55 500 230 500 255 500 317 638 55

95° 90° 90°

AGE (an-mois)
AGE (year-month)
ALTER
IDADE
LEEFTIJD
ETA - EDAD

5 – 12

120 mm

16544P6
16544P1

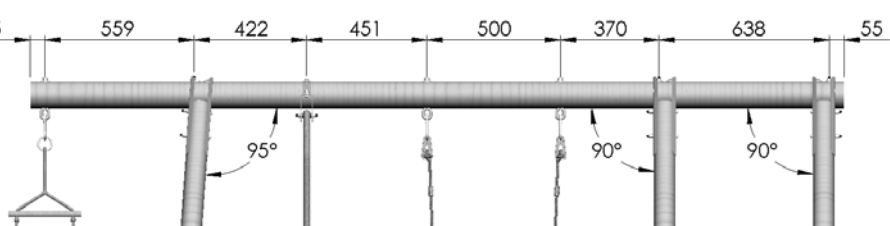

55 559 422 451 500 370 638 55

95° 90° 90°

AGE (an-mois)
AGE (year-month)
ALTER
IDADE
LEEFTIJD
ETA - EDAD

5 – 12

120 mm

16652P6

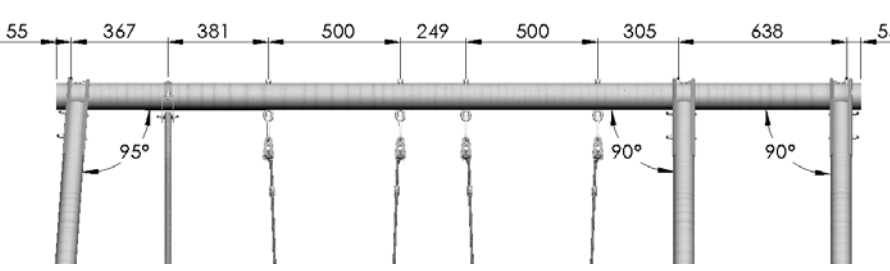

55 367 381 500 249 500 305 638 55

95° 90° 90°

AGE (an-mois)
AGE (year-month)
ALTER
IDADE
LEEFTIJD
ETA - EDAD

5 – 12

180 mm

16654P6

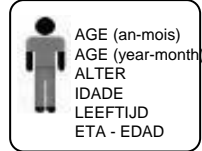
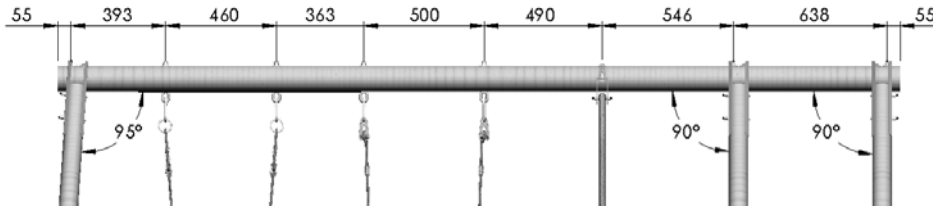

5 – 12

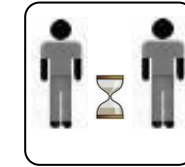

16546P6

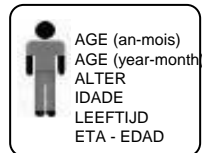
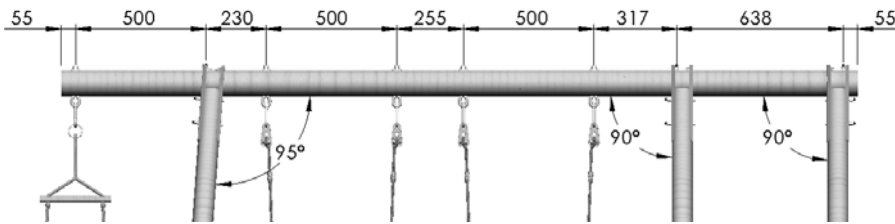

9 mois
(siège bébé)
12 ans

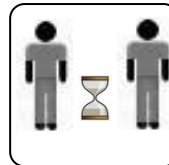

F – Procéder à l'assemblage des pièces avec la visserie, **sans serrer**. Une fois assemblé entièrement, serrer définitivement toutes les vis. Ensuite, sceller **impérativement** votre portique. Pour un portique 6 pieds, l'angle formé par la poutre et les 4 pieds formant la plate-forme doit être de 90°. Par contre l'angle formé par la poutre et les 2 pieds restants doit être au moins de 95° vers l'extérieur. Le non respect de ces consignes risque d'endommager votre produit et annulera la garantie.

GB – Use the screws to assemble the pieces but without **tightening them**. Once entirely assembled tighten all the screws definitively. It is then **essential** to firmly anchor your frame. For frames with 6 legs the angle between the beam and the 4 legs forming the platform should be 90°. However, the outer angle between the beam and the 2 remaining legs should be.

DE – Die Einzerteile mit Hilfe der Schrauben zusammenbauen, dabei die Schrauben **erst nur lose anziehen**. Sobald alles zusammengabaut wurde, alle Schrauben festziehen. Anschließend muss das Gerüst **unbedingt** fest verankert werden. Bei einem Gerüst mit 6 Füßen muss der Winkel zwischen dem Balken und den 4 Füßen, die die Plattform bilden, 90° betragen. Allerdings muss der Außenwinkel zwischen dem Balken und den beiden verbleibenden Füßen mindestens 95° betragen. Wenn diese Vorschriften nicht beachtet werden, besteht das Risiko, dass der Artikel beschädigt wird und die Garantie erlischt.

NL – Ga verder mt het samenstellen, stuk per stuk, door gebruik te maken van de schroeven, **zonder deze aan te draaien**. Wanneer alles gemonteerd is, kunt u de schroeven complete aandraaien. Maak hierna uw speelconstructie heel steig hast. Bij een speelconstructie met 6 poten, moet de hoek gevormd door de balk en de 4 poten die het platvorm ondersteunen, 90° zijn. Bovendien moet de hoek gevormd door de balk en de resterende 2 poten, 95° zijn naar nuiten to.

ES – Proceda a ensamblar las piezas con tornillos y pernos, **sin ajustar**. Una vez que haya realizado el ensamblado complete, ajuste definitivamente todos los tornillos. A continuación, es **obligatorio** que selle el portico. Para un pórtico 6 pies, el ángulo entre la viga y los 4 pies que forman la plataforma debe ser de 90°. En cambio, el ángulo formado por la viga y los 2 pies restantes debe ser, como mínimo, de 95° hacia el exterior.

IT – Procedere all'assemblaggio dei pezzi con viti e bulloni, **senza stringere**. Una volta completato l'assemblaggio, stringere definitivamente tutte le viti. In seguito, sigillare **obbligatoriamente** la struttura. Per una struttura a 6 piedi, l'angolo formato dalla trave e dai 4 piedi della piattaforma deve essere di 90°. L'angolo formato dalla trave e dai 2 rimanenti piedi deve invece essere di almeno 95° verso l'esterno.













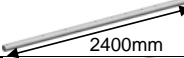



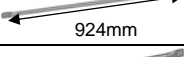

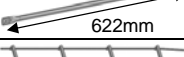



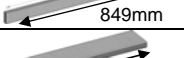

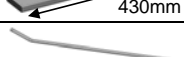







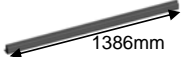











PO – Procederà montagem das peças com os parafusos, **sem apertar**. Um avez montado completamente apertar definitivamente todo os parafusos. Em seguida, fixar **imperativamente** o seu pórtico. Para o pórtico 6 pés, o ângulo formado pela trave e os 4 pés que formam a plataforma deve ser de 90°. Por outro lado, o ângulo formado pela trave e os 2 pés restantes deve ser de pelo menos 95° para exterior.

Pour plus d'informations, vous pouvez vous rendre sur notre site internet WWW.TRIGANOJARDIN.COM

A compter du 01/12/2011, simplifiez-vous la vie en vous inscrivant sur notre site internet afin de valider votre carte de garantie

Réf., Rif., Art., Nr., Ref.

Quantité, quantità, anzahl, quantity, aantal, cantidad, quantidade

TOPWOOD 2,30m		TOPWOOD 2,30m					TOPWOOD 2,30m		TOPWOOD 2,30m				
		Réf. 16541P6 Réf.16541P1	Réf. 16544P6 Réf.16544P1	Réf. 16552P6	Réf. 16654P6	Réf. 16546P6			Réf. 16541P6 Réf.16541P1	Réf. 16544P6 Réf.16544P1	Réf. 16652P6	Réf. 16654P6	Réf. 16546P6
	125 508	125 506	125 509	125 516	125 508		150 777 27	6	6	6	6	6	
	125 198	6	6	6	6		152 810	6	6	6	6	6	
	122 846	1	1	1	1		Poelier Ø6x45 - 121 011	-	2	2	2	-	
	150 100 17	1	1	1	1		Poelier Ø6x55 - 121 013	-	4	4	4	-	
	151 108 17	3	3	3	3		H Ø8x20 - 121 110	-	2	2	2	-	
	122 522-2	1	1	-	-		H Ø8x100 - 121 134	12	12	12	12	12	
	125 191	2	2	2	2		H Ø8x120 - 121 135	3	3	3	3	3	
	125 186	12	12	12	12		Poelier Ø8x70 - 121 030	-	2	2	2	-	
	151 117 17	-	-	-	-		TRCC Ø8x55 - 121 209	-	2	2	2	-	
	151 168 17	-	2	2	2		Ø8x60 - 121 311	20	21	21	21	20	
	150 006 17	-	1	1	1		Ø8x100 - 121 313	8	8	8	8	8	
	150 020 17	-	1	1	1		Ø3,5x35 - 405 307	50	50	50	50	50	
	125 185	2	2	2	2		Ø8 - 121 505	12	12	12	12	12	
	122 830	-	2	2	2		Ø6 - 121 511	-	6	6	6	-	
	122 570-1	4	2	4	2		Ø8 - 121 512	15	21	21	21	15	
	En option : 122 840-1	4	2	4	2		Ø6 - 121 602	-	6	6	6	-	
	122 502-1	-	2	2	2		Ø8 - 121 603	58	67	67	67	58	
	480U	-	-	-	1		Ø8 nylon - 121 609	-	2	2	2	-	
	122 834	2	1	2	1		122 506	-	4	4	4	-	
	122 035	5	3	4	4		122 536	-	2	2	2	-	
	122 819-1	8	8	8	8		122 623	-	4	4	4	-	
	9710 / 9720	1	-	-	-								

REF.	(A)
16541P6 16541P1	125 508
16544P6 16544P1	125 506
16546P6	125 508
16652P6	125 509
16654P6	125 516

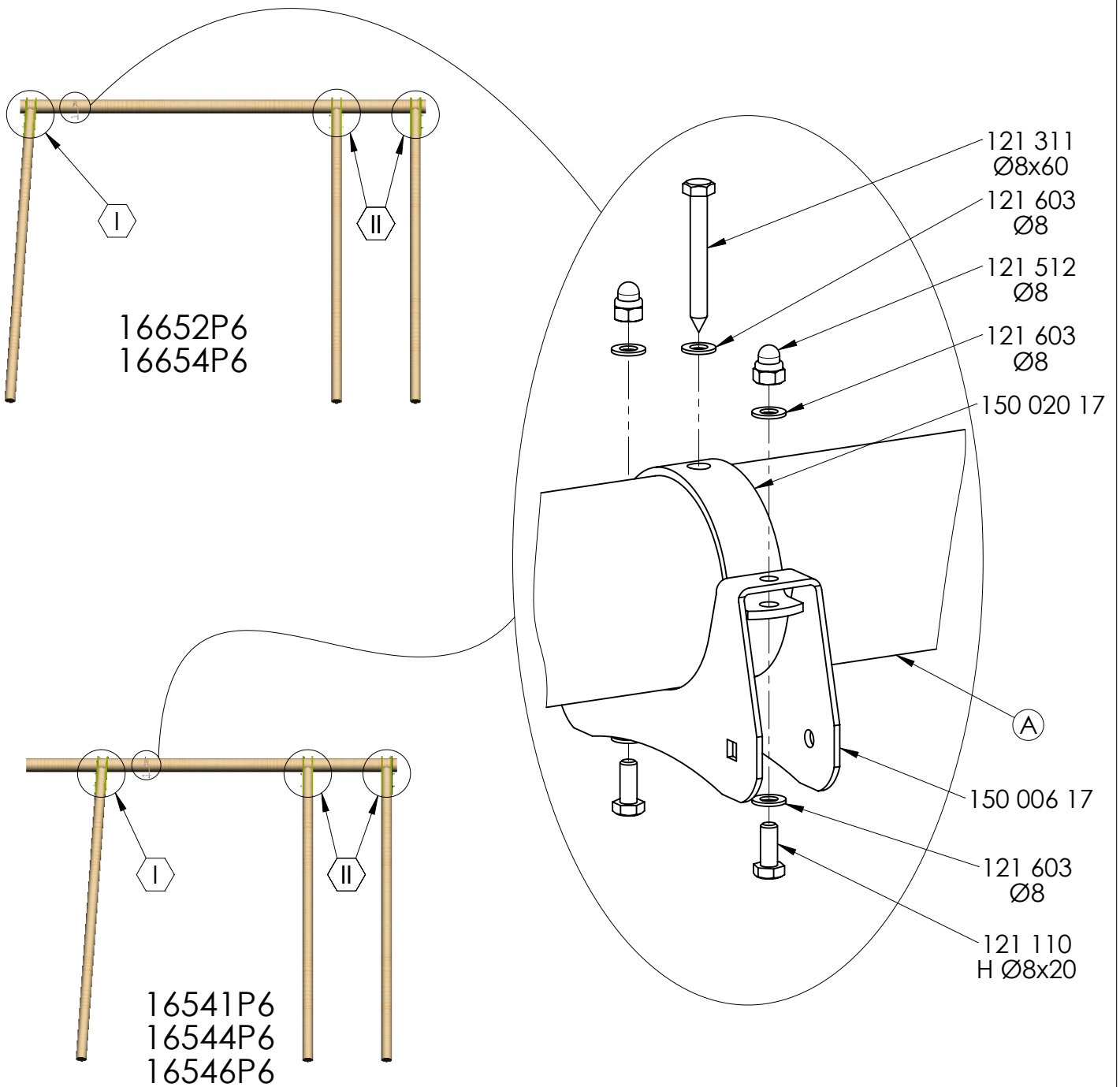

1

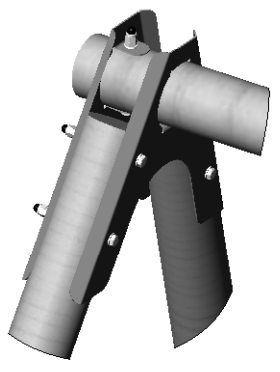

1

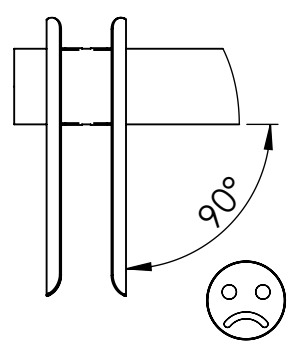
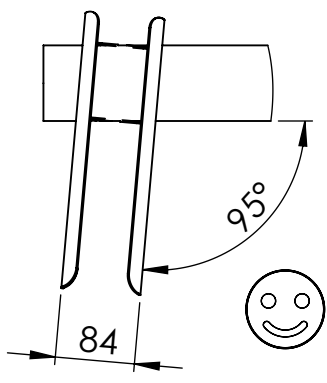

2

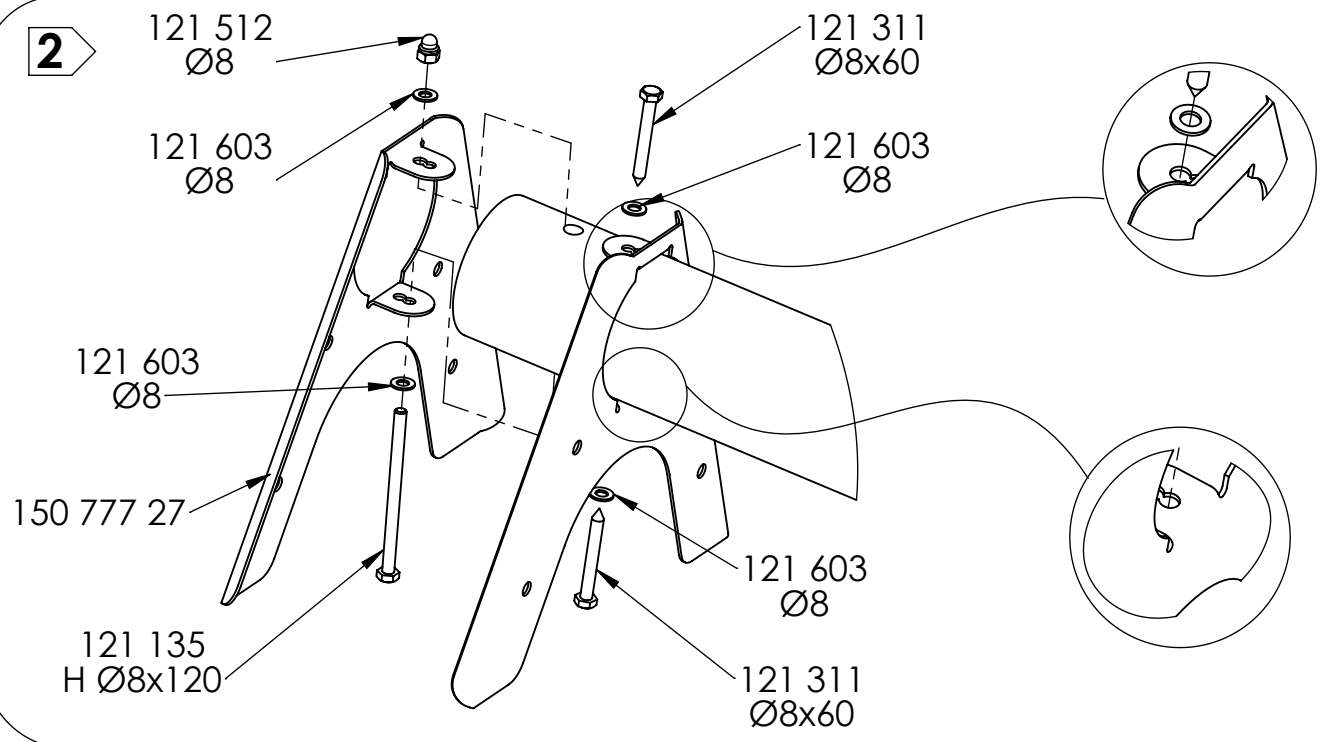

3

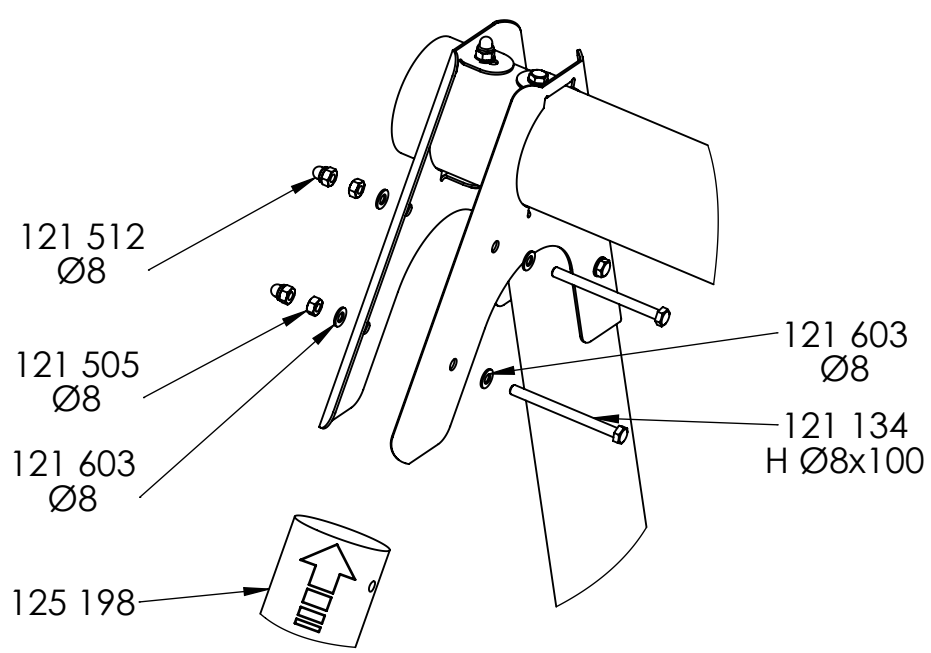

II

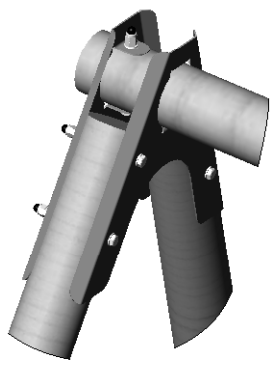

1

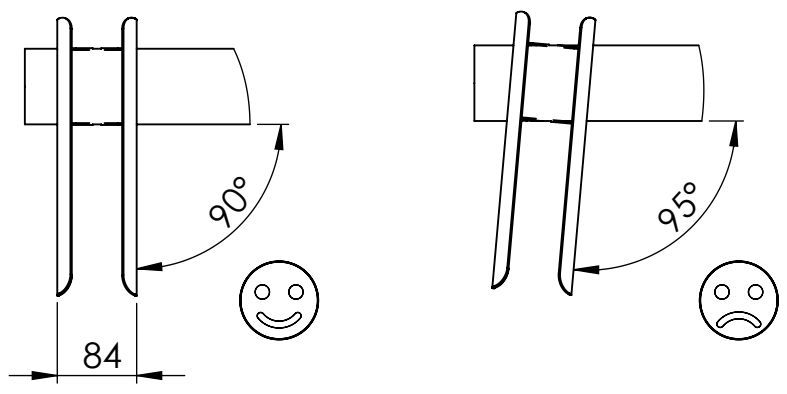

2

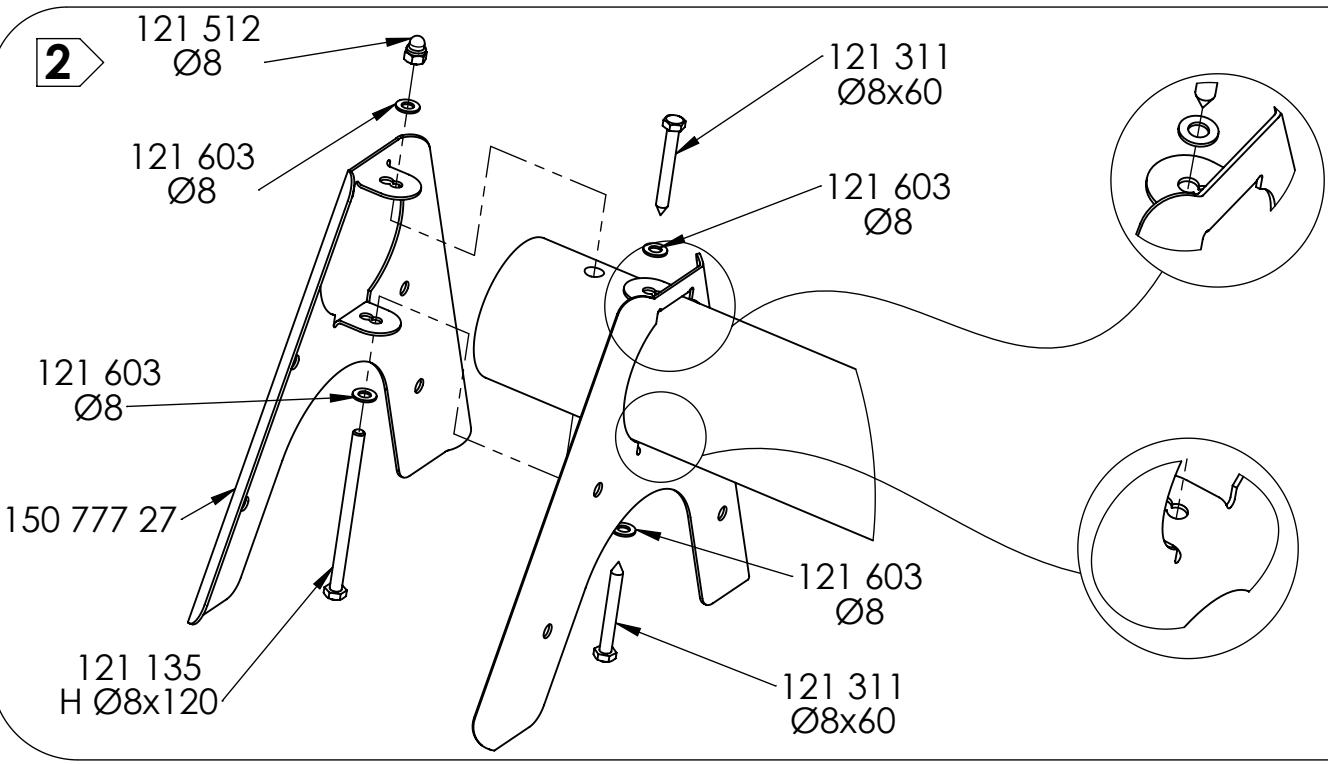

3

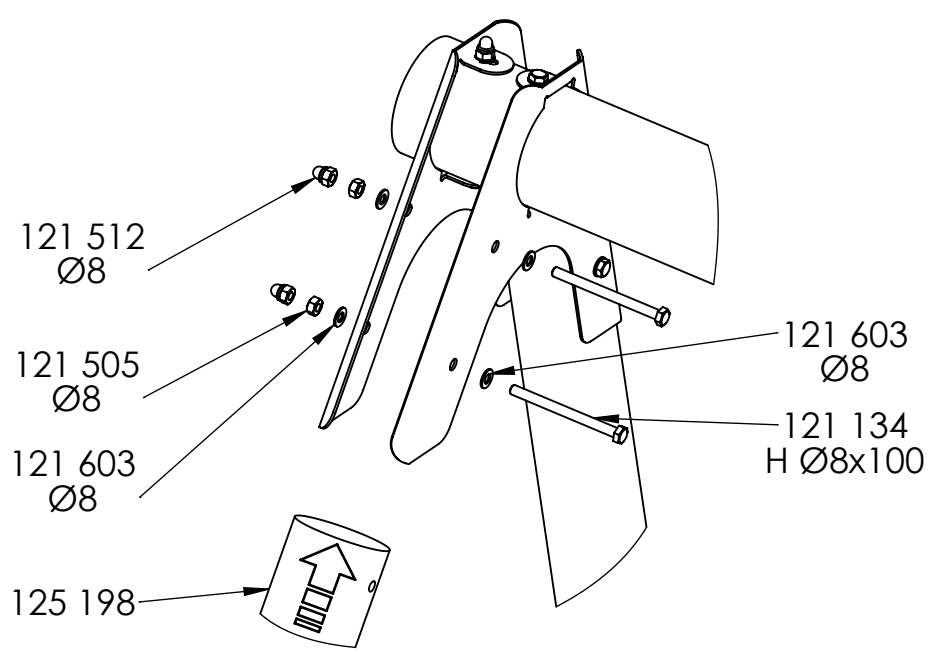

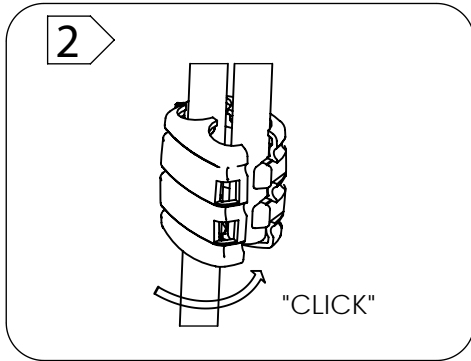

1

X 2

Ø	(A)	(B)	(C)	(D)
80	122 037	121 617	121 617	121 509
100	122 035		121 616	121 530

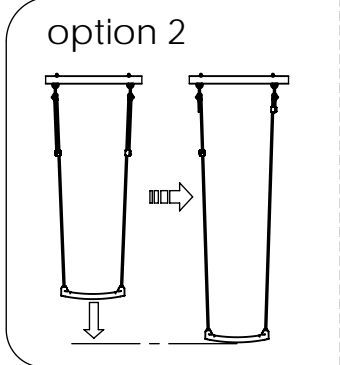
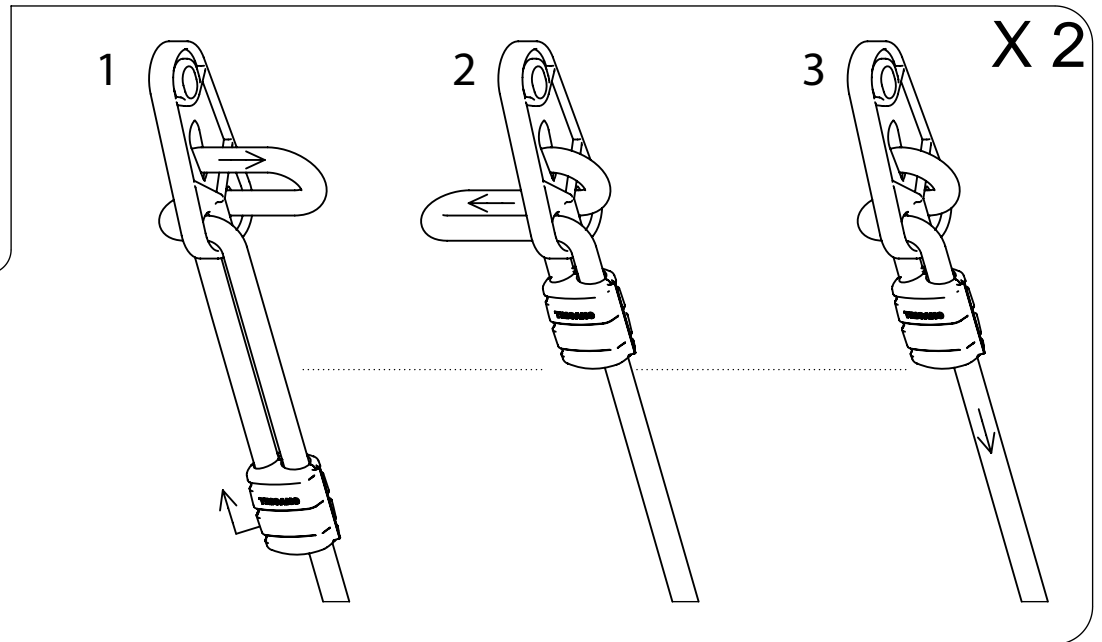
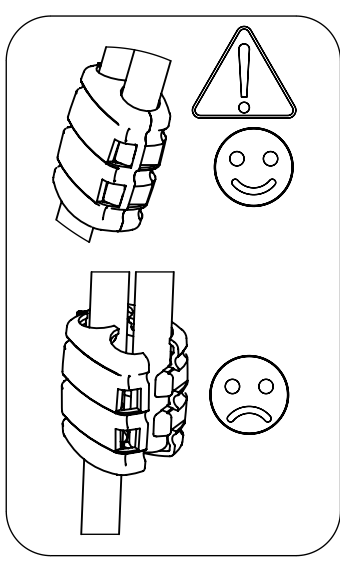
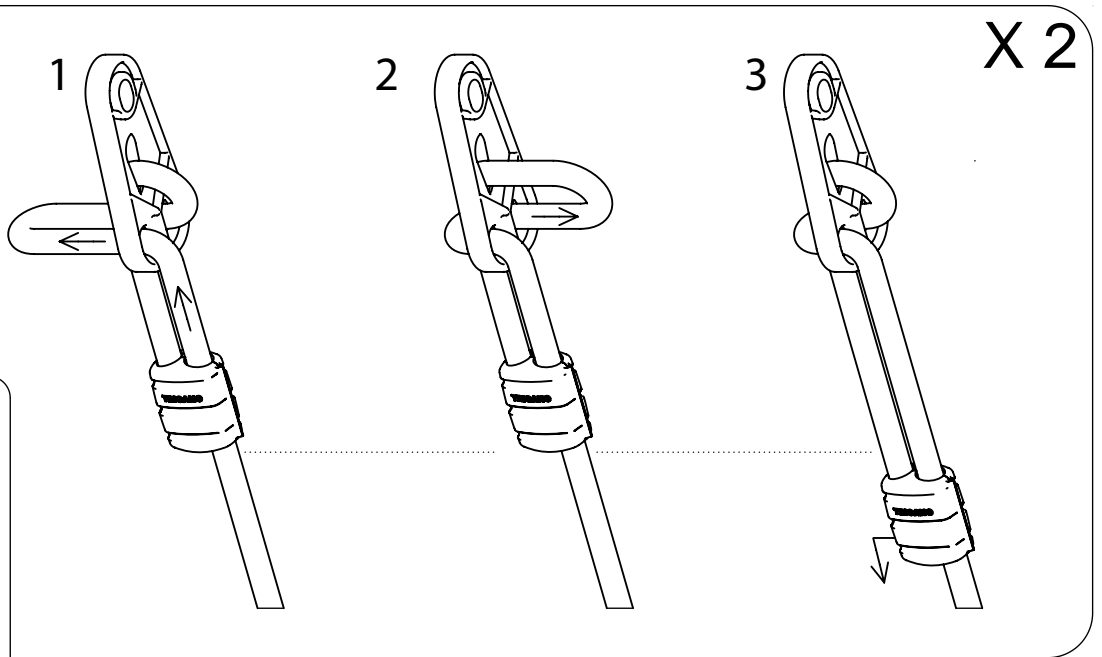
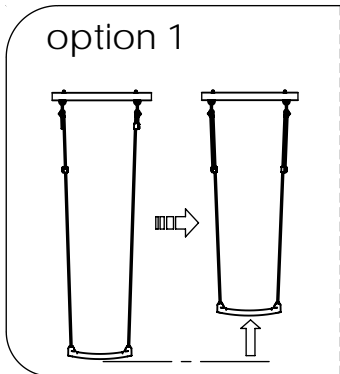

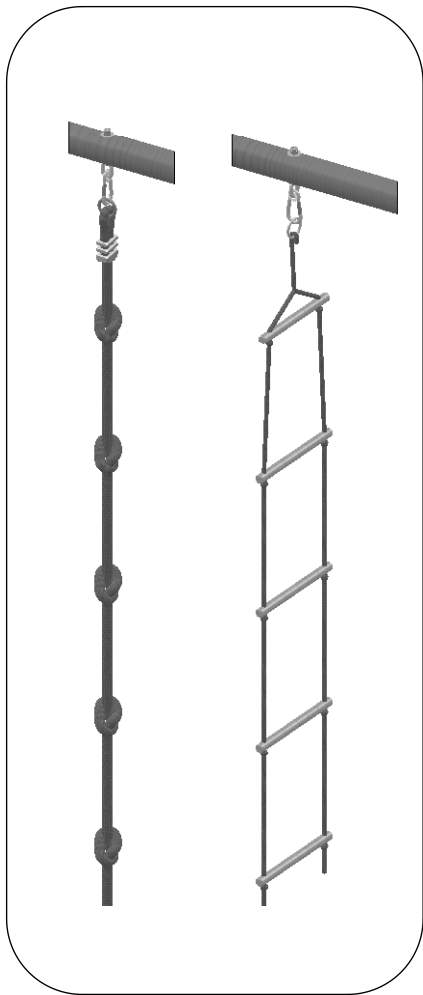

∅	(A)	(B)	(C)	(D)
80	122 037	121 617	121 617	121 509
100	122 035		121 616	121 530

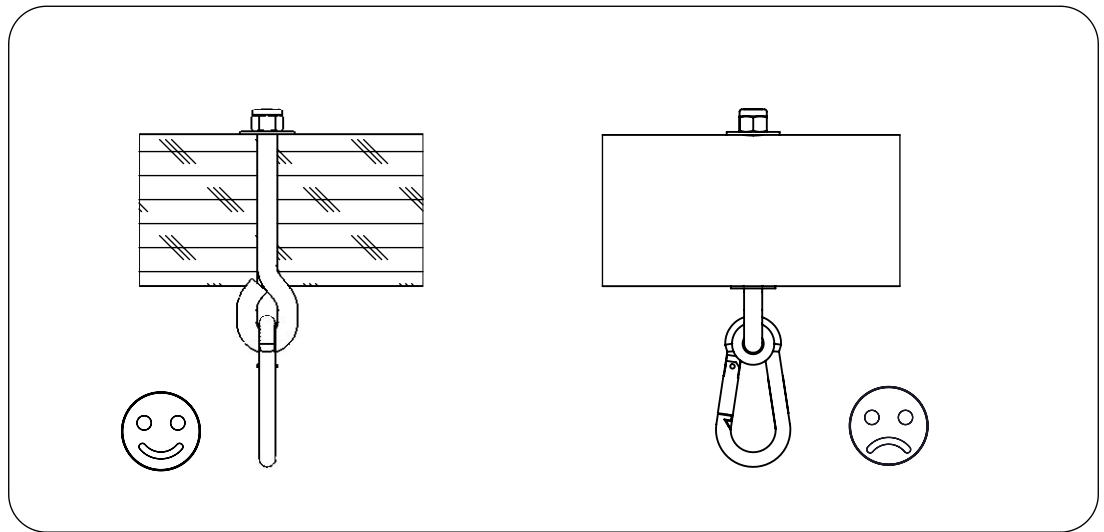

∅	(A)	(B)	(C)	(D)
80	122 037	121 617	121 617	121 509
100	122 035		121 616	121 530

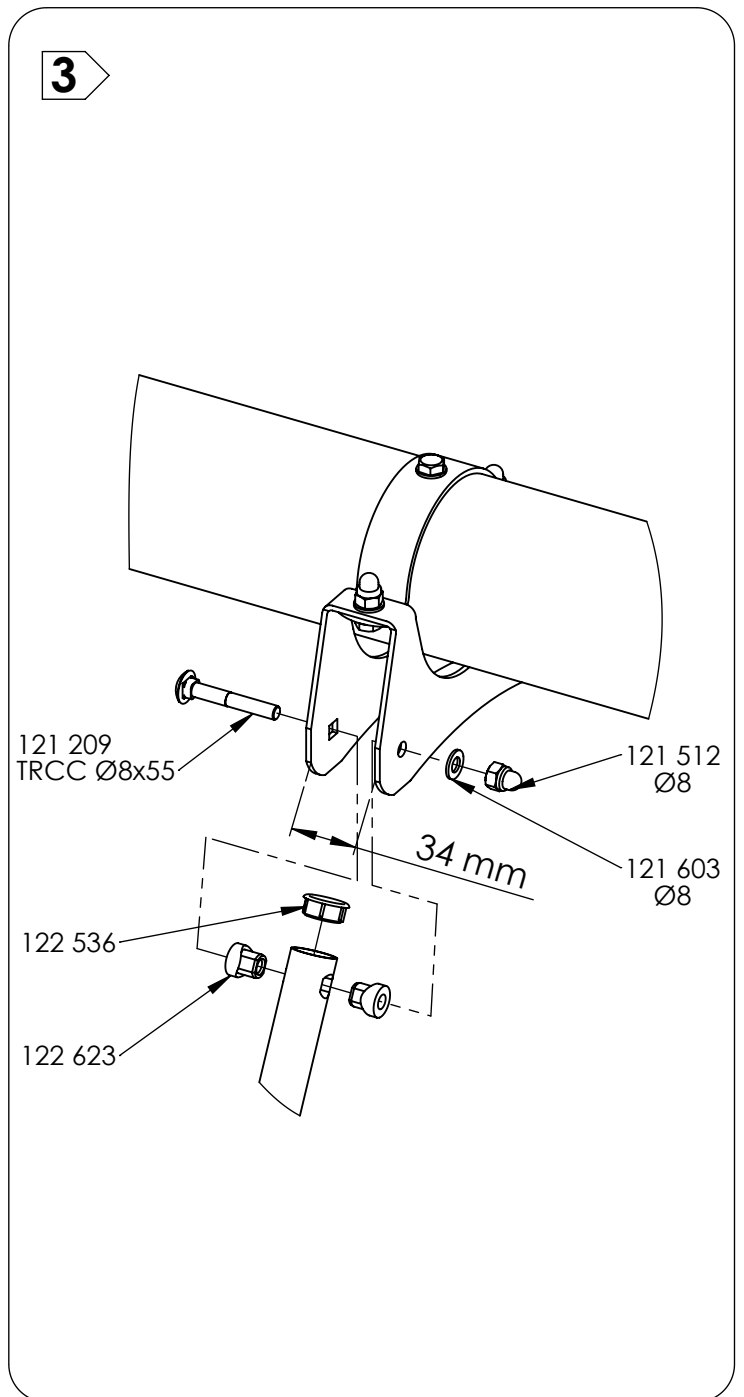
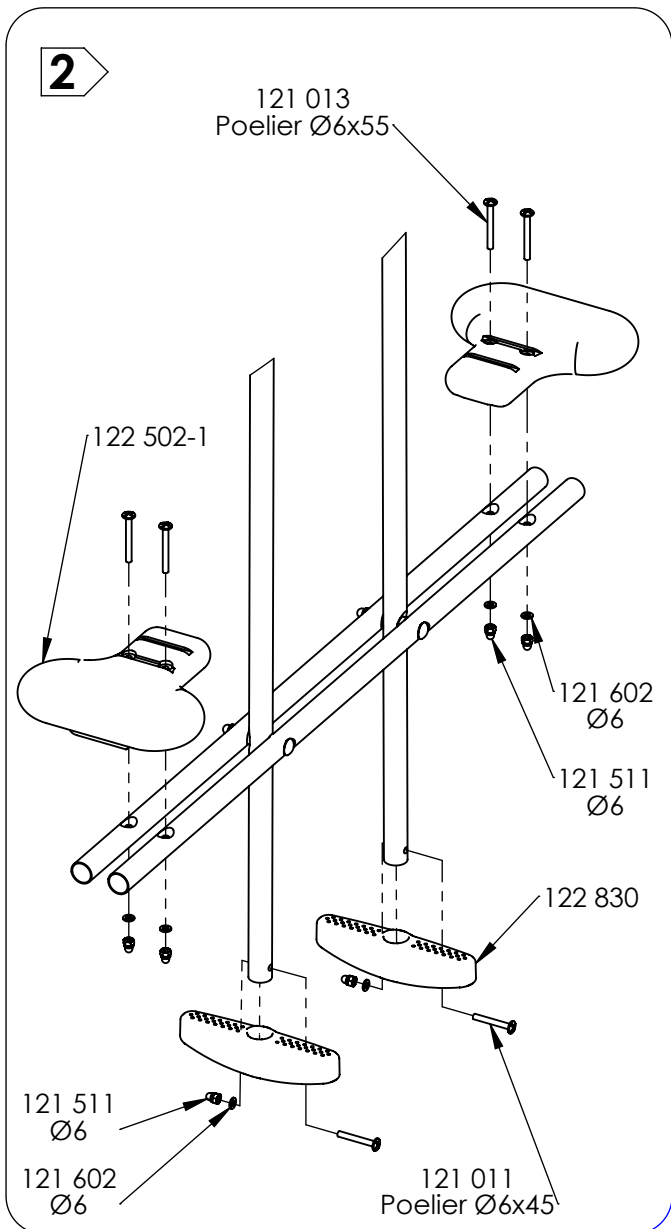
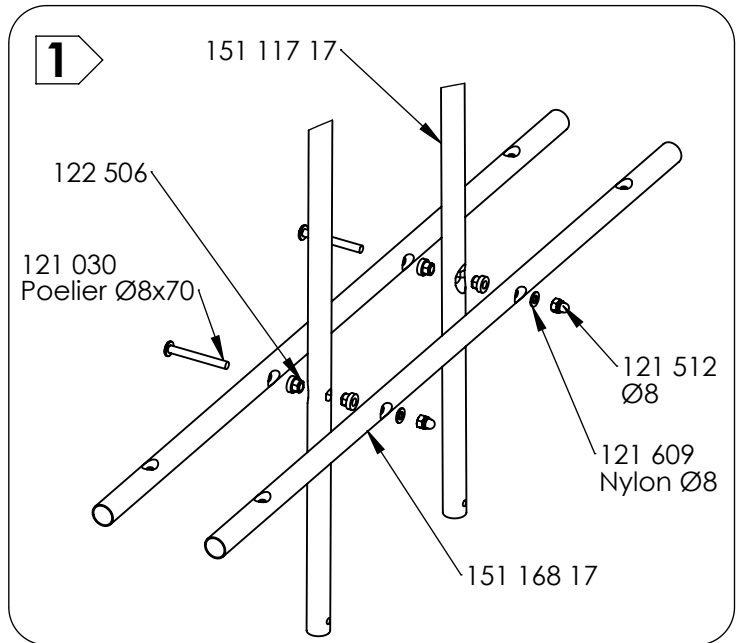

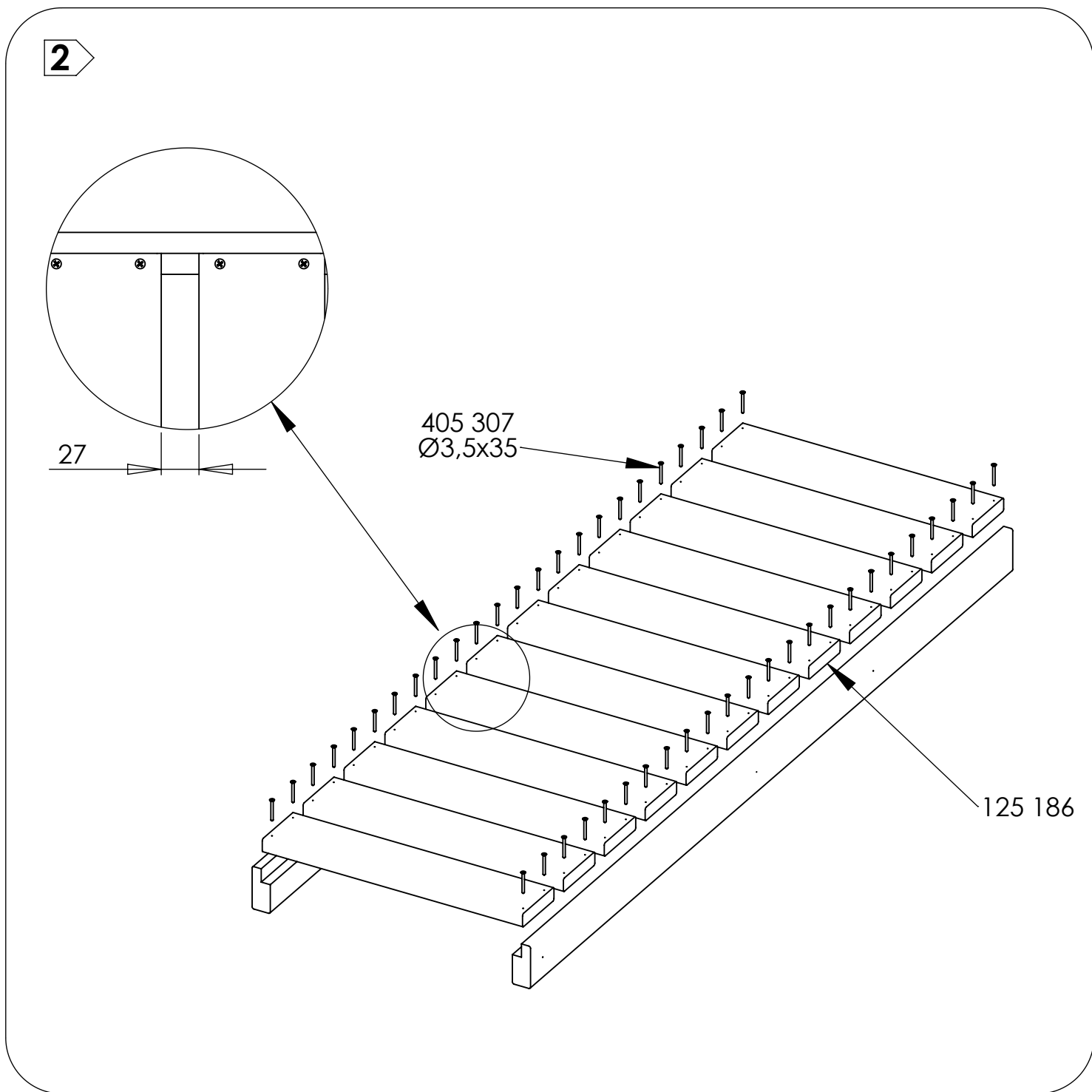
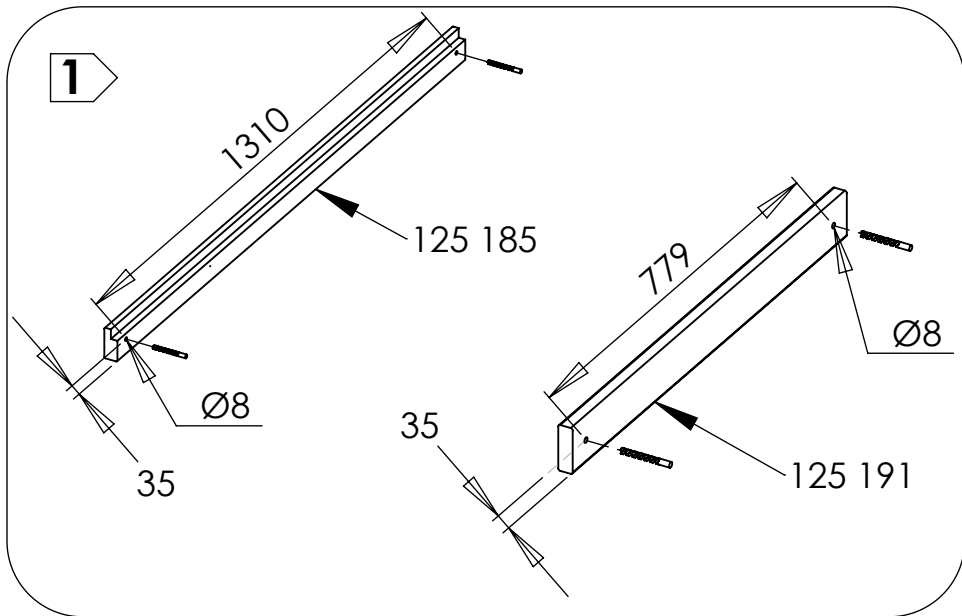

3

